

HIGH EFFICIENCY CLASSIFICATION

The CCE Classifier is designed for use in the fine particle separation range (i.e. sub sieve) with particular attention given to the requirements for particle separations in the less than 15 micron range. It is common knowledge that the key to good particle separation in this range is dispersion. Dispersion in close proximity to the separation zone with a minimum of confusion is a requisite. The CCE Classifier design incorporates an optimized feed introduction, which maximizes the effectiveness of the dispersion forces and minimizes distortion of the particle trajectories within the vortex field, thus improving the solids loading capability at a given particle size separation.

The air and solids flow patterns through the CCE Classifier are shown in Figure 1. The classifier housing serves as a plenum into which the metered primary air is introduced through the inlet duct. This air enters the classifier rotor through the narrow gap between the tip of the two rotor halves and the stator. These opposing high velocity streams form a turbulent dispersing zone. Feed enters the system through the central tube, which is angled to the radial to minimize the distance of coarse particle injection into the vortex due to inertia. The space between the outer edge of the blades and the periphery of the rotor forms the classification zone. Coarse product, which is rejected outward by the centrifugal field, is conveyed out of the classifier through the coarse outlet using a jet pump mounted on a cyclone. The cyclone overflow is returned to the classifier through the recycle port. Fine product leaves the classifier through the central outlet with the primary airflow.

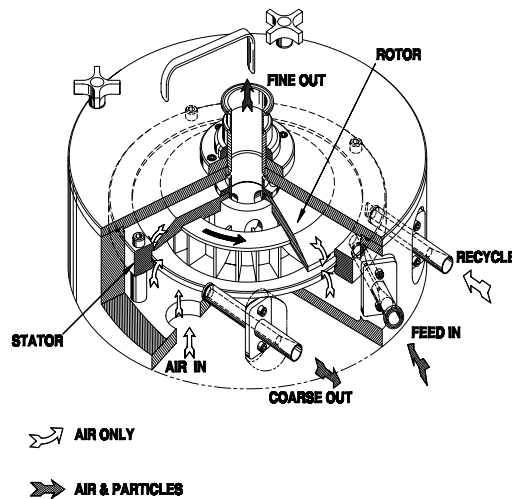

Figure 1

The space between the outer edge of the blades and the periphery of the rotor forms the classification zone. Coarse product, which is rejected outward by the centrifugal field, is conveyed out of the classifier through the coarse outlet using a jet pump mounted on a cyclone. The cyclone overflow is returned to the classifier through the recycle port. Fine product leaves the classifier through the central outlet with the primary airflow.

The CCE Classifier falls under the definition of centrifugal air classifiers, which utilize the opposing forces of centrifugal and drag to achieve a separation. The general theory depicting a single particle within an idealized flow field has been well documented in published literature. The centrifugal air classifier is as follows:

$$D_{50} = \frac{3k}{\pi D_0 N} \sqrt{\frac{\mu Q}{\pi H \rho_p}}$$

Where D_{50} is the "cut size", k is a constant dependent on the flow pattern (determined experimentally). D_0 is the diameter of the separation zone, H is the height of the separation

zone, μ is fluid viscosity, Q is volumetric airflow rate, N is rotor rotational speed and ρ_p is true particle density.

In practice this relationship can be used to determine trends, for example:

- Increasing rotor speed decreases cut size.
- Increasing fluid flow rate increases cut size.
- Decreasing particle density increases cut size.

General classifier operation varies from theory primarily due to the flow pattern existing within a given vortex configuration and by the mere fact that particle concentration is greater than one. For a given vortex field one can define an empirical value for k within limits of particle concentration (feed rate) that will allow prediction of classifier performance.

Based on the definition of a centrifugal classifier, at some point the outwardly directed centrifugal force and the inwardly directed drag force on a particle are equal. This critical particle diameter, which has an equal probability of entering either the coarse or fine fraction, is known as the "cut size" (D_{50}). Determination of the cut size and the classifier performance (sharpness) is best accomplished by using the size selectivity method. This method is outlined in the AIChE Equipment Testing Procedure entitled "PARTICLE SIZE CLASSIFIERS, A GUIDE TO PERFORMANCE EVALUATION" 1980. (American Institute of Chemical Engineers).

In brief, size selectivity can be expressed as a fraction as follows:

$$\eta_d = \frac{\text{quantity of size D entering coarse fraction}}{\text{quantity of size D in feed}}$$

where η_d is classifier selectivity and D is particle size. Mathematically by mass:

$$\eta_d = \frac{W_c d \phi_c}{W_o d \phi_o} = \frac{W_c d \phi_c}{W_c d \phi_c + W_f d \phi_f}$$

where ϕ_c is the cumulative percent by mass of coarse fraction less than size D , ϕ_o is percent less than size D in feed, W_c is coarse fraction mass flow rate, W_f is fine fraction mass flow rate & W_o is feed mass flow rate.

The necessary size selectivity data can be obtained from a particle size distribution analysis of the fine and coarse fraction and the mass balance of a given classification. The incremental form of the above equation is used to calculate the size selectivity. A plot of this data results in the size selectivity curve. The equiprobable cut size, D_{50} , corresponds to the 50 % value on this curve.

The shape of the curve represents the sharpness of separation or, in other words, the spread of misplaced material. An index related to the shape of the selectivity curve is the ratio:

$$\beta = D_{25}/D_{75}$$

where β is the sharpness index, D_{75} the particle size corresponding to the 75% classifier selectivity value and D_{25} to the 25% value. Perfect classification $\beta = 1$, the smaller the β , the poorer the classification.

The size selectivity, or grade efficiency, plot shown in Figure 2 is typical of a separation that can be obtained using a Model 250 Classifier to classifier to classify a minus 30 μm silica feed. Size distributions were measured using a Coulter Multisizer.

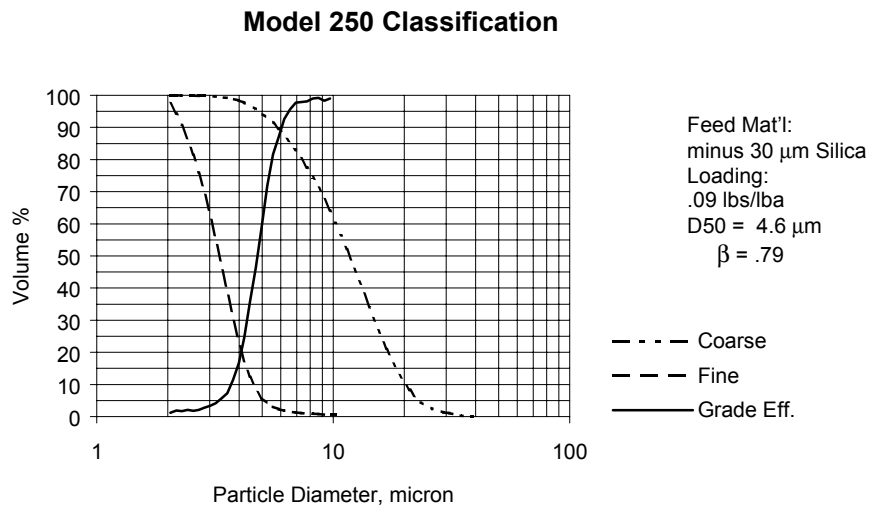

Figure 2

Overall Classification Performance: (Ref.: Particle Size Classifiers, AIChE)

A short cut method for expressing classification performance on a specific feed material. A practical measurement of overall classification performance for a given application can be obtained by calculating recovery and yield. Recovery is the relative amount of material in the feed of the desired size (either coarser or finer than a given size D) that is recovered in the product. Recovery expressed as a fraction of the feed can be calculated from cumulative particle size distribution data as follows.

When the fine fraction is the product:

$$R_{Df} = \frac{w_f \phi_f}{w_0 \phi_f}$$

When the coarse fraction is the product:

$$R_{Dc} = \left[\frac{w_c(1-\phi_c)}{w_o(1-\phi_o)} \right]$$

Yield is a measure of product obtained irrespective of quality and is calculated as a fraction of feed by:

$$\text{Fine yield} \quad Y_f = \frac{w_f}{w_o} = 1 - Y_c \qquad \text{Coarse yield} \quad Y_c = \frac{w_c}{w_o} = 1 - Y_f$$

For cases in which w_c and w_f cannot be measured, yield can be estimated from size distributions if mass balance is assumed:

$$Y_c = \frac{\phi_f - \phi_o}{\phi_f - \phi_c} \quad \text{and} \quad Y_f = \frac{\phi_o - \phi_c}{\phi_f - \phi_c}$$

Classifier Operation:

The CCE Classifier is very predictable in performance and its operation will correspond to the "cut size" equation within limits of solids loading for most feed materials.

Based on the general theory outlined in the introduction, the following empirical relationships have been derived for the:

Model 100 Classifier:

$$D_{50} = \frac{4048}{N} \sqrt{\frac{Q}{\rho_p}}$$

Model 250 Classifier:

$$D_{50} = \frac{1524}{N} \sqrt{\frac{Q}{\rho_p}}$$

Model 500 Classifier:

$$D_{50} = \frac{805}{N} \sqrt{\frac{Q}{\rho_p}}$$

where D_{50} , cut size is in microns, N , rotor speed is in rpm, Q , air flow, is in cubic feet per minute and ρ_p , particle density is in grams per cc. This relationship can be used to select

the original operating conditions for each of the classifier models when processing a given material.

Figure 3 shows the calculated cut size versus rotor speed in comparison to data obtained from classification of silica, ($\rho_p = 2.65 \text{ gm/cc}$), at solids loading less than $.05 \text{ lb}_s/\text{lb}_a$. During normal use of the classifier the solids loading or particle concentration is considerably higher than the $.05 \text{ lb}_s/\text{lb}_a$ noted above. The higher solids loading will result in shifting

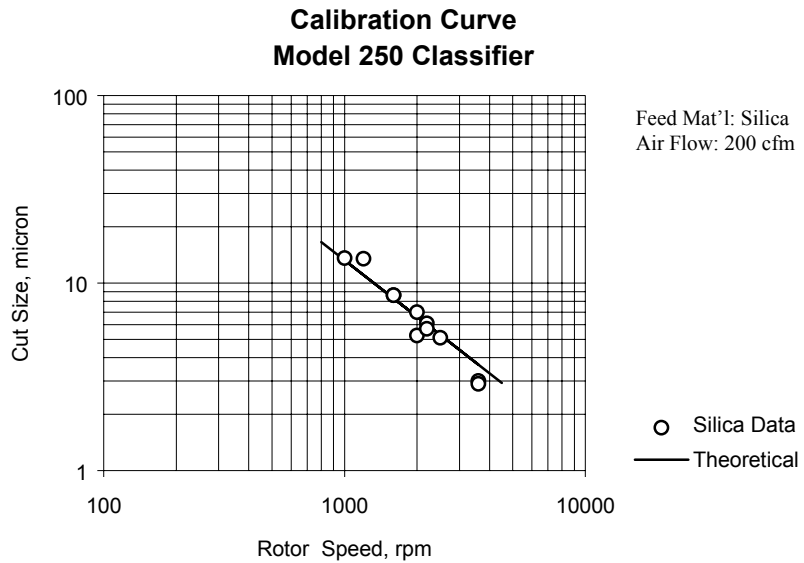

Figure 3

the cut size finer, (*a characteristic of a forced vortex*), this can be compensated for by reducing the rotor speed to compensate. This procedure will extend the performance range to the point of maximum particle concentration at a given cut size.

Figure 4 shows a typical classifier system. Included are the bare essentials required for operation such as: Flow source, product collection (fine and coarse) and feed system. Variations from this setup are application dependent, such as a fine product cyclone collector, type of bag house, etc.

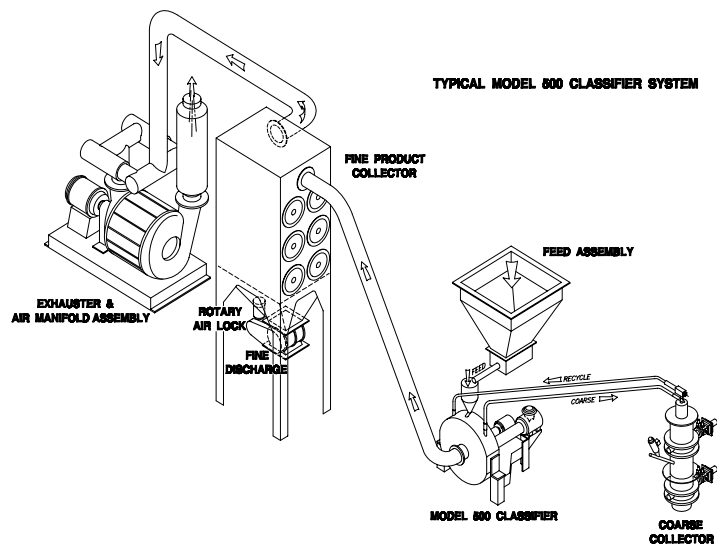

Figure 4