

# High Efficiency Centrifugal Air Classifiers



The AVEKA CCE Centrifugal Air Classifier is designed to separate fine particles in the less than 75 $\mu$ m range utilizing the opposed forces of centrifugal and drag in close proximity to a high intensity dispersion mechanism. The Classifier incorporates an optimized feed introduction which maximizes the effectiveness of the dispersion forces and minimizes distortion of the particle trajectories within the vortex field. This allows the classifier to achieve a precise, predictable, and extremely sharp separation at a high solids loading. The Model 100 Classifier system is the ideal tool for the production of lab size samples, product development and/or small quantity production. Both the Model 250 and 500 offer the laboratory precision at production rates.

**AVEKA CCE Technologies, LLC**

# Operating Principal

The flow patterns through the AVEKA CCE Classifier is described as follows: Feed enters the system through the central tube, which is angled to the radial to minimize the distance of coarse particle injection into the vortex due to inertia. The space between the outer edge of the blades and the periphery of the rotor forms the classification zone. Coarse product, which is rejected outward by the centrifugal field, is conveyed out of the classifier through the coarse outlet using a jet pump mounted on a cyclone. The cyclone overflow is returned to the classifier through the recycle port. Fine product leaves the classifier through the central outlet with the primary air flow.

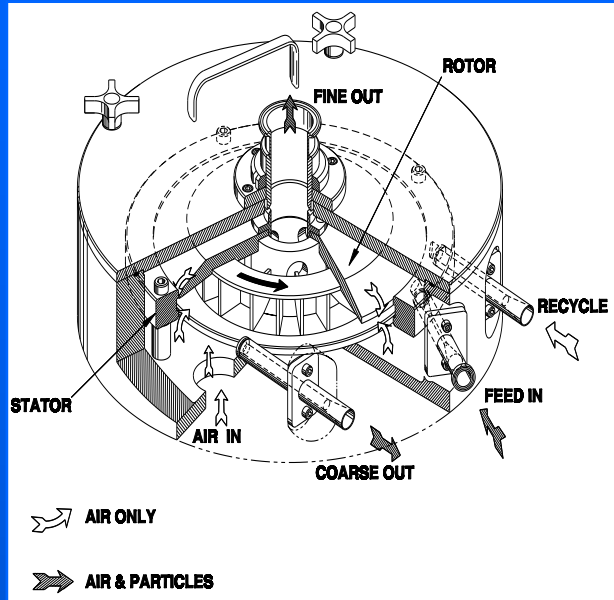

Our Classifiers come complete with all the major components necessary for classification of dry powders in the less than 75 micron size range. A typical system includes the classifier assembly, flow source, coarse and fine fraction collectors, feed system, and controls. Component selection and design are application specific to meet your requirements.

AVEKA CCE Technologies maintains lab facilities for customer testing, equipment evaluation, and custom processing.

## Equipment Specifications

Model No	100	250	500
<b>PERFORMANCE RANGE*</b>			
Cut Size (D50), Microns**	1-30	1-50	2-50
Sharpness (D25/D75)	.6-.8	.6-.8	.6-.8
Feed Rate, lbs./hr.	to 30	to 500	to 2000
*Depending on feed material characteristics, desired cut size, and solids loading.			
**At particle density of 2.6 gms./cc.			
<b>OPERATING RANGE</b>			
Rotor Speed rpm	700-7000	400-4000	360-3600
Primary Air Flow, scfm	to 70	to 250	to 800
Max. Operation Vac, In. Hg	12	12	12
Rotor Drive, HP	1.5	3	15
Primary Flow Source, HP	7.5	25	75
Compressed Air scfm @100 psig	6	12	40

## AVEKA CCE Technologies, LLC

ultrafine grinding and separating

7555 95th Street South, Cottage Grove, MN 55016

(651) 688-2656 FAX: (651) 688-8989

www.avekacce.com

Pulverization • Classification • Custom Processing • Particle Size Analysis • Complete Systems Engineering • Consulting